

APPENDIX D

Standards for Docks on the Canal System

**NEW YORK STATE THRUWAY AUTHORITY/
NEW YORK STATE CANAL CORPORATION**

**STANDARDS FOR DOCKS
ON THE CANAL SYSTEM**



NEW YORK STATE CANAL CORPORATION

MAY 2001

BUREAU OF MANAGEMENT ANALYSIS AND PLANNING

TAP-915 (05/01)

TABLE OF CONTENTS

<u>SECTION</u>	<u>PAGE</u>
I. Introduction	1
II. Application	1
III. Standards	1
A. Navigation.....	1
B. General.....	2
C. Environmental.....	3
IV. Appendix.....	4
V. Distribution.....	5

STANDARDS FOR DOCKS ON THE CANAL SYSTEM

I. INTRODUCTION

Section 100 of the Canal Law authorizes the Canal Corporation to "issue revocable permits granting certain limited privileges therein, whenever the same can be done without detriment to Canal navigation or damage to the banks or other structures thereof." The purpose of this document (the "Standards") is to provide specific standards for docks on the Canal System.

II. APPLICATION

The Standards shall apply to residential/non-commercial docks, which can accommodate four or fewer boats, each of which shall not exceed 40 feet in length, with a maximum dock length of 100 feet.

Commercial docks, as well as docks larger than the size standard established above, will be analyzed on a case-by-case basis.

The Standards apply to the Erie, Champlain, Oswego and Cayuga/Seneca Canals (i.e., the areas under Canal Corporation jurisdiction). Docks on reservoirs and feeder canals will be considered by the Canal Corporation on a case-by-case basis.

Any new dock installations or extensions to current docks will require a work permit.

III. STANDARDS

A. NAVIGATION

No dock shall interfere with Canal navigation, by either physically impeding navigation or obstructing the vision of boaters traveling on the Canal System.

1. Minimum offset from edge of navigation channel (bottom angle):
 - a. River section: 50 feet minimum offset.
 - b. Land cut section: 24 feet minimum offset (16 feet clear area plus 8 feet nominal boat width). Where a 24 feet offset is physically impossible, a dock with 4 feet maximum projection from the shoreline is allowable.
 - c. On curved sections of the Canal, the Canal Corporation may require greater offsets than the offsets set forth in a. and b., to account for sight distance or vessel maneuverability considerations. The Division Canal Engineer may designate certain limited areas where docks are prohibited for navigation reasons.

STANDARDS FOR DOCKS ON THE CANAL SYSTEM

2. Docks shall be parallel to shore in land cut areas.
3. Docks shall be at least 50 feet from Canal Corporation navigation aids.
4. Docks and moored boats shall not hinder boaters' views of navigation aids or structures on the Canal System.
5. Protection of the dock and moored boats from passing boat wakes is the permittee's responsibility. Boats shall not be moored on the outer (Canal) side of wake protection devices.
6. Docks and slips shall have their design approved by the Division Canal Engineer. A standard approved dock design is attached as Appendix A.
7. Excavated slips are not permitted where:
 - a. The Canal is in an embankment section;
 - b. An unstable or unsafe condition would be created; or
 - c. The Division Canal Engineer determines that there is insufficient Canal Right-of-Way, or a future trail would be impeded.
8. No dock installation will be permitted which may impair the integrity of an embankment.
9. Slips, cuts, etc., must be lined with stone bank protection, riprap, or other method for protection against erosion and wave action as approved by the Canal Corporation.

B. GENERAL

1. One dock per property owner (residential) is permitted. More than one dock shall be treated as a commercial dock installation.
2. Docks and decks shall not restrict access (e.g., for trails, maintenance or operations) across Canal lands.
3. Docks shall be set back at least 10 feet from property lines of adjacent upland owners. Extensions of property lines across Canal Corporation property to the water shall be as determined by the Canal Corporation.
4. No new boathouses will be permitted.
5. Covered slips may have a roof only – no sides are permitted.

STANDARDS FOR DOCKS ON THE CANAL SYSTEM

6. Excavated slips, where permitted, shall be no larger than 1,000 sq. feet.
7. All electrical and plumbing services to docks, slips and decks shall meet all applicable local, state and federal codes.
8. No enclosed storage shall be permitted on docks or decks.
9. Flotation devices for docks shall be foam blocks, pontoons or other material manufactured specifically for flotation. Metal barrels, drums, or other containers that are not specifically made for flotation are prohibited.
10. Retaining walls, when a part of a dock request, shall be constructed of stone, concrete blocks, poured concrete or other materials acceptable to the Canal Corporation. Railroad ties, vehicle tires, creosote timbers, guide railing, and asphalt are not permitted.

C. ENVIRONMENTAL

1. Any dock with more than four boat moorings or 100 linear feet of dockage will require an independent environmental review under the State Environmental Quality Review Act (SEQRA).
2. No creosote or pentachlorophenol shall be allowed.
3. Slips or other excavations shall require a letter of no effect from the State Historic Preservation Office before permit issuance.
4. Slips or other excavations will require appropriate sampling and disposal of materials as directed by the Canal Corporation.
5. Fills are prohibited within the limits of an established floodway, flowage easement or flood plain, unless mitigation measures approved by the Canal Corporation and all other appropriate state and federal agencies are included.

STANDARDS FOR DOCKS
ON THE CANAL SYSTEM

IV. APPENDIX

APPENDIX A

(Reduced from Sheet Size 8-1/2" x 11")

APPENDIX A - DOCK ALONG CANAL

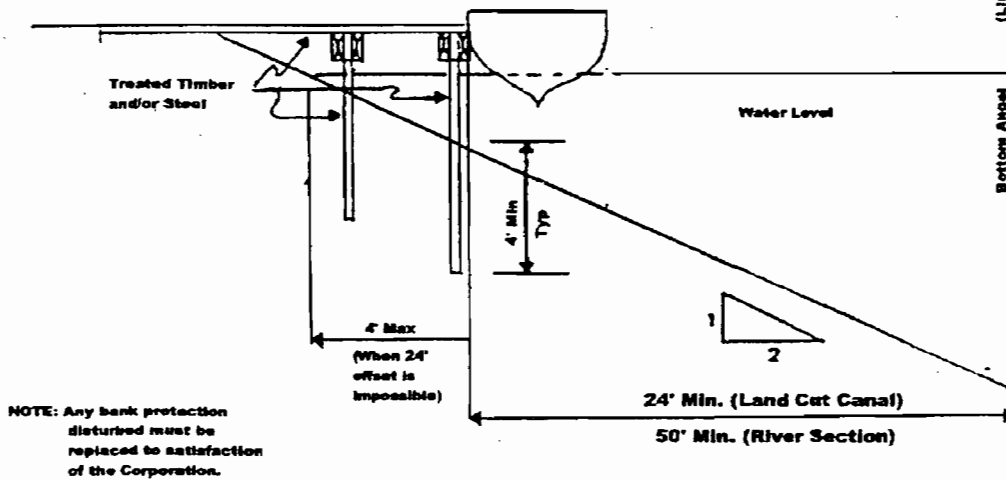
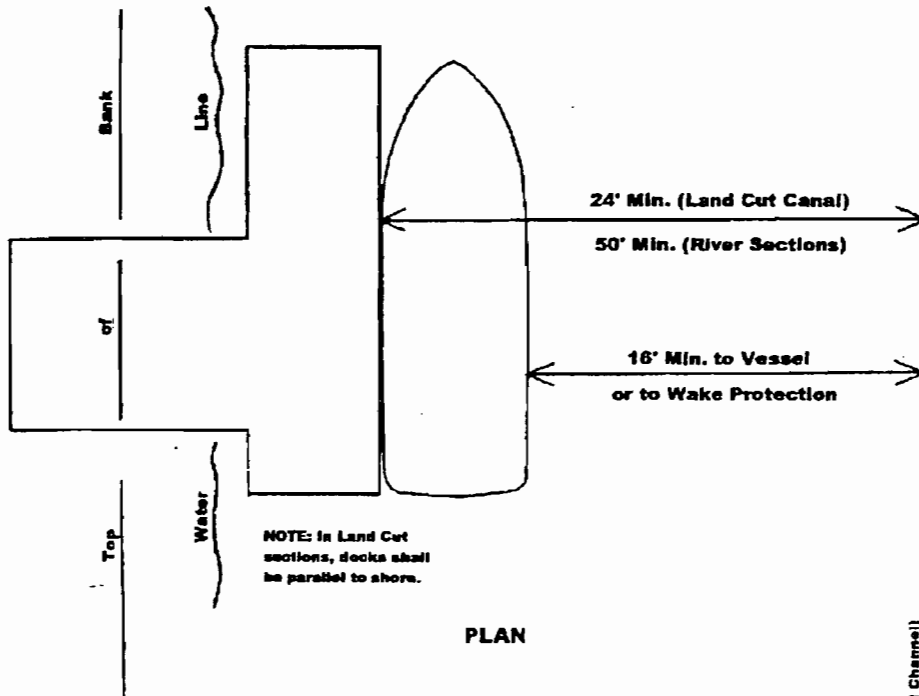

V. DISTRIBUTION

Executive Director
Deputy Executive Director
Department Heads
Deputy General Counsel
Chief Assistant Counsel, Legal Services
Assistant Counsels, Legal Services (4)
Director of Human Resource Management
Director of Labor Relations
Director of Investments and Asset Management
Supervisor of the Bureau of Real Property Management
Director of Design
Director of Canal Design
Director of Canals Maintenance and Operations
Canals Administrative Officer
Supervisor, Canal Engineering and Capital Program
Director of the Bureau of Environmental Management and Historic Preservation
Director of Canal Development
Director of Canal Marketing
Director of Canal Policy Implementation
Division Directors
Division Canal Engineers
Division Canal Section Superintendents
Division Canal Permit Coordinators
Division Canal Right-of-Way Agents